

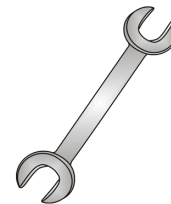

# Tow-Trust Towbars

Important: Please read General Notes overleaf before fitting



Issue 6

**TA1011 AUDI A6 SAL 2004 – 2011**  
**AUDI A6 AVANT EST 2005 – 2011**  
**AUDI A6 ALLROAD QUATTRO EST 2006 - 2011**

Item	Qty	Description	Item	Qty	Description
A	1	Crossmember	E	2	M16 x 50 Bolts, Nuts & S/P Washers
B	2	Side Arms	F	2	M12 x 85 Grade 10.9 Bolts & Nyloc Nuts
C	1	Extension Bar	G	4	M10 x 100 Bolts, 2 Nuts & 4 S/P Washers
D	2	25 x 65 Spacer	H	2	M10 x 30 Bolts & S/P Washers
			J	2	M14 x 110 Bolts & Nyloc Nuts
			K	4	14 x 27 Flat Washers
			L	4	12 x 25 Flat Washers
			M	6	10 x 30 Flat Washers
			P	1	Socket Plate 1

1. Remove boot floor and storage boxes and plastic back panel, ease side panels enough to reveal Towbar mounting points.
2. Remove mud flaps if fitted.
3. Remove the rear bumper three fixings around wheel arch, two fixings on lower edge, two fixing through back panel and two nuts inside boot beneath light clusters.
4. Cut a section **CENTRALLY** from the lower edge of the bumper 65mm wide x 115mm deep. SEE SKETCH.
5. Remove the bumper beam. (This is not refitted with the towbar.)
6. Temporarily lower the rear exhaust silencer.
7. Locate item **B** into the open ends of each chassis, using item **G** with item **M** loosely bolt into place.
8. Using item **H** bolt and fully tighten item **A** to items **B**.
9. Using item **J** and item **K** bolt item **A** through the vertical point to item **B**.
10. Fully tighten all nuts and bolts and ensure the towbar is rigid and secure.
11. Refit exhaust silencer.
12. Re-fit the rear bumper. (Take care not to break top central bumper locator)
13. Using item **F** with item **L** bolt item **C** and item **P** to item **A**.
14. Using item **E** bolt the ball bracket (not supplied in this kit) to the mounting plate, fully tighten all remaining nuts and bolts
15. Refit rear trim inside the boot.

**Note:**

1. Recommended Torque Setting for M12 Grade 10.9 -139 Nm. (For other Torque Settings see notes overleaf.)
2. Nose load limits and vehicle manufacturer's trailer / caravan weight limits must be observed.

BUMPER CUT DETAILS ( THIS IS NOT A SCALED TEMPLATE )

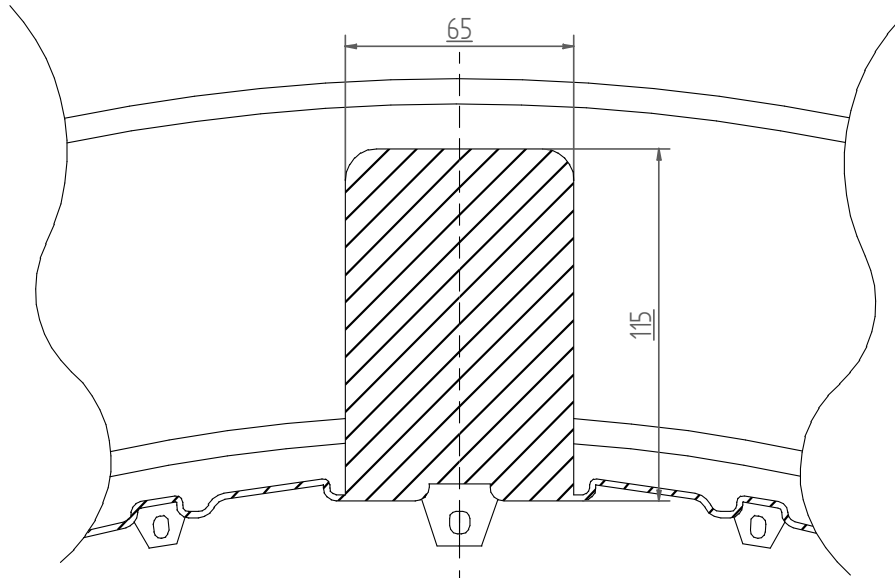

TA 1011

