

TAD6 Audi A6 (C8) 2018> A6 allroad (C8) 2019> A7 (F2) 2018>

Item	Qty	Description	Item	Qty	Description
A	1	TAD6 Crossmember	D	2	M16 x 50 Bolts & Nyloc Nuts
B	2	Handed Side Arms	E	2	M12 x 60 Bolts & S/P Washers
C	1	Extension	F	6	M12 x 40 (10.9) Bolts, 4 Nyloc Nuts & 2 S/P Washers
			G	1	M12 x 100 Bolt & Nyloc Nut
			H	2	M12 x 40 Bolts & Nyloc Nuts
			J	4	12 x 30 Flat Washers
			K	12	12 x 25 Flat Washers
			L	1	30mm O/D x 34.5mm Long Spacer Tube
			M	4	100 x 2.5 Black Zip Ties
			N	1	M10 x 30mm Bolt & Nyloc Nut
			P	2	10 x 25 Flat Washer

Bumper Removal.

1. Remove rear light clusters by removing the black inner plastic trim to reveal two fixings per light cluster.
2. Remove three fixings from each wheel arch, peel back wheel arch liner to reveal one tip fixing either side. Remove six fixings along bumper lower edge.
3. Carefully release the bumper from the vehicle body and pull rearwards disconnecting any necessary wiring looms.
4. Remove the rear impact beam (this is not refitted with the Towbar assembly). Replace fixings into rear panel to prevent water ingress.
5. As per Fig 3 Use Item N with Items P to prevent water ingress. As per Fig 2 cut the heat shield, NOTE: Some models are pre-cut.

Towbar Installation.

1. Insert Items B into each correct chassis member and fix through the rearmost mounting point using Item F with Item J, fix at the forward mounting point using Item E with Item J.
2. Fix Item A between each side arm using Items F with Items K.
3. Fix Item C to Item A using Items H with Items K and Item G with Items K ensuring Item L is fitted between the lowest mounting point.
4. Fully tighten all fixings ensuring the Towbar is rigid, square and secure.
5. Cut the rear bumper as per Fig:1 Relocating the boot sensor cable when applicable and refit. NOTE: Some models are pre-cut.
6. Using Item D fix your desired ball bracket and wiring plate (Not supplied in this kit) to Item C and fully tighten.

Fig:1
Bumper Cut Inside View

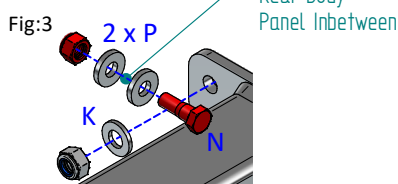
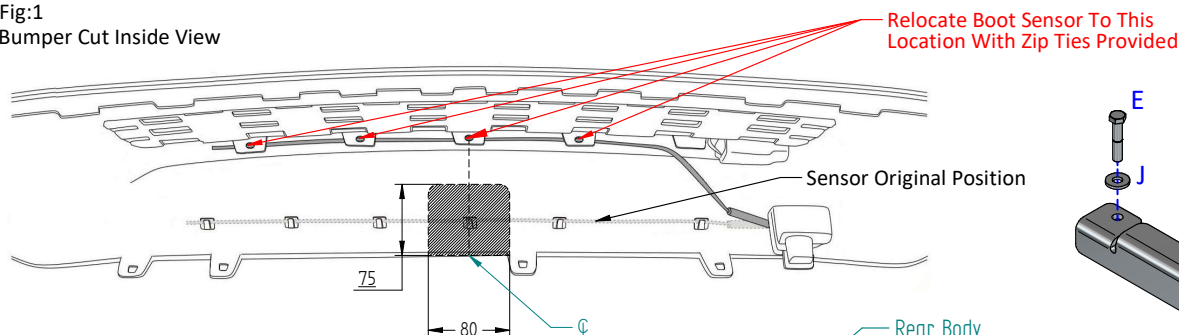
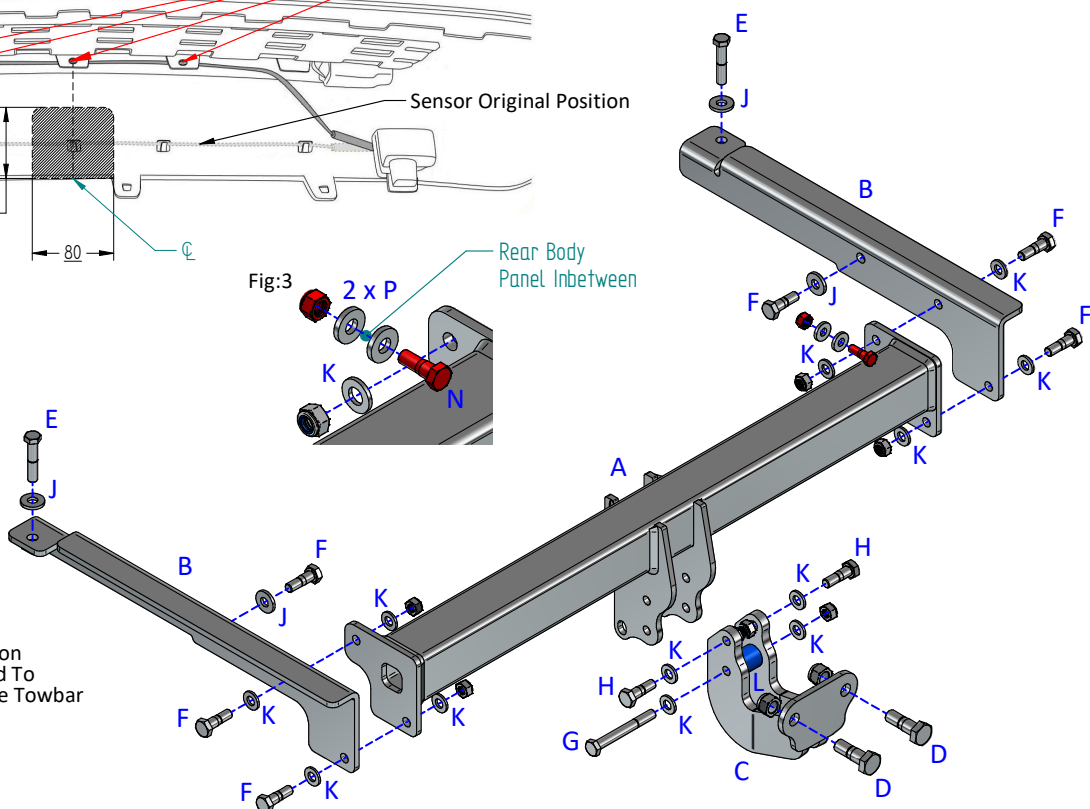
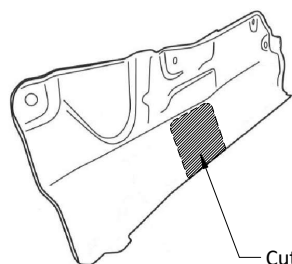

Fig:2



Notes:

1. For Torque settings see general notes overleaf.
2. Nose load limits and vehicle manufacturer's trailer / caravan weight limits must be observed.