



Tow-Trust Towbars

Important: Please read General Notes overleaf before fitting



Issue 4

TBM4SN BMW X3 (F25) (G01) / X4 (F26) (G02)

Item	Qty	Description	Item	Qty	Description
A	1	Crossmember	C	2	M12 x 110 Grade 10.9 Bolts & Nyloc Nuts
B	1	ACS2 / 9202 Swan Neck	D	2	15mm Spacer Plates
			E	4	12 x 25 Flat Washers
			F	6	Large Plastic Rivets
			G	1	VASP8 L/H Socket Plate
			H	2	Handed Exhaust Hangers (G01 Models Only)
			J	2	M8 x 25 Bolts & Nyloc Nuts
			K	2	8 x 20 Flat Washers
			L	4	12 x 30 Flat Washers

BUMPER REMOVAL:

1. Remove the rear light clusters (Remove plastic trim to reveal two fixings on F25 & three fixings on G01).
2. Remove three fixings from each wheel arch, remove wheel arch trim this will reveal two fixings, locate and remove.
3. Remove two fixings along the lower edge found by each wheel arch. Remove undertray (Nine fixings), Remove the reflectors from bumper to reveal one fixing and remove. Remove one fixing each side around light cluster, pull bumper tips outward to release from body.
4. Remove the four fixings securing the plastic bumper supports and remove from vehicle. (These will be refitted after Towbar assembly).
5. Remove the rear impact beam and retain gaskets & fixings (Item X). (Impact beam will NOT be refitted with the Towbar assembly).

TOWBAR INSTALLATION:

1. Refit the gaskets from the impact beam to the studs on the rear panel.
2. Using Items X and Items L fit Item A to the studs on the rear panel and fully tighten (98 Nm). G01-G02 models will require Item H to be sandwiched between the rear panel and Item A.
3. Using Item C with Item E and Item D fix Item B and Item G to Item A.
4. Using Item J with Item K rehang the G01-G02 exhausts to Item H. Refit plastic inner bumper support to Items H.
5. Fully tighten all nuts and bolts ensuring Towbar is rigid square and secure.
6. Refit the rear bumper using Items F around each wheel arch.
7. Cut the undertray as per sketch and refit.

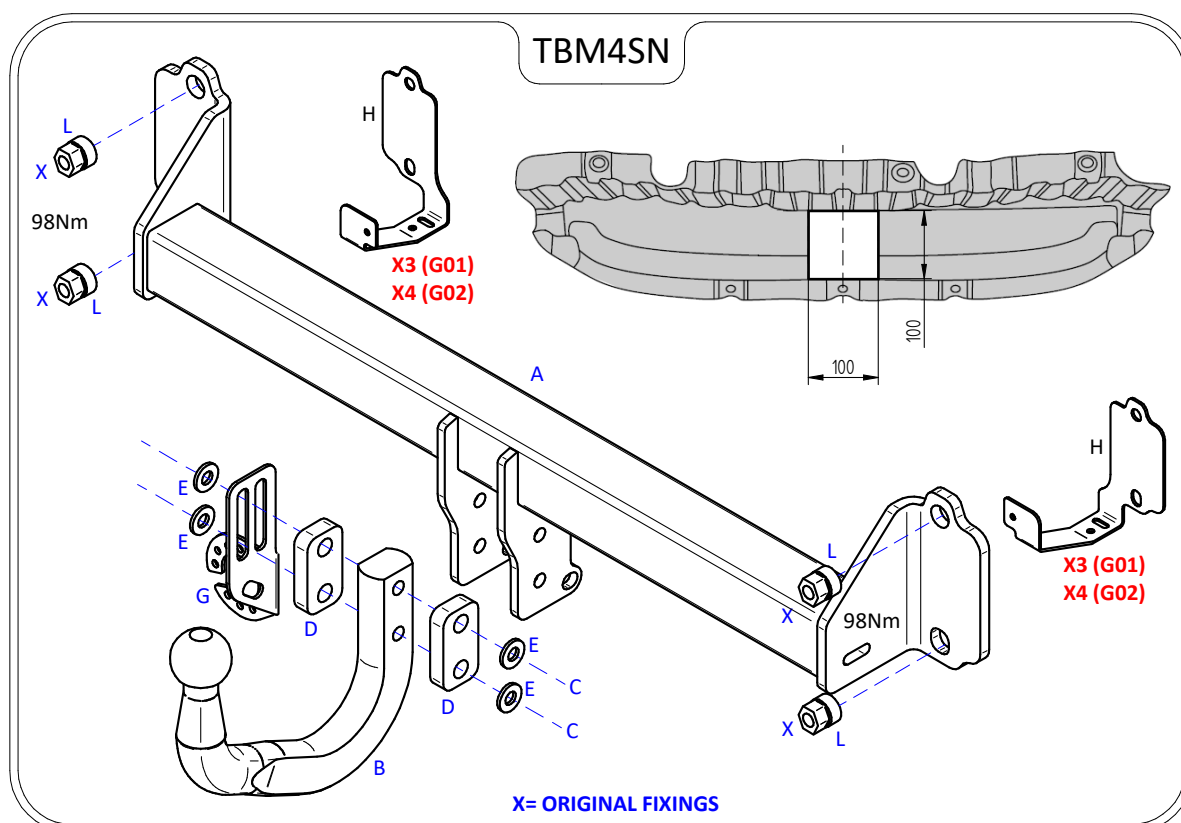

- Note:**
1. Recommended Torque Setting for M12 Grade 10.9 -130 Nm. (For other Torque Settings see notes overleaf.)
 2. Nose load limits and vehicle manufacturers trailer / caravan weight limits must be observed.