

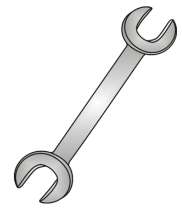

# Tow-Trust Towbars

Important: Please read General Notes overleaf before fitting



Issue 3

## TBMW6 BMW 5 SERIES SAL (F10), EST (F11) & GT 2010>

Item	Qty	Description	Item	Qty	Description
A	1	Crossmember	C	2	M16 x 40 Bolts, Nuts & S/P Washers
B	1	Extension bar	D	4	M12 x 40 Bolts & Nyloc Nuts
			E	1	Flip Up Socket Plate (TTFP/RH)
			F	4	12 x 25 Flat Washers
			G	2	M8 x 30 Bolts, Nuts & S/P Washers
			X	4	BMW Original Nuts
			H	4	12 x 40 Flat Washers

### SALOON & ESTATE BUMPER REMOVAL

Remove the fixings securing the rear light side trims, remove trims and remove the bumper fixing hidden behind, remove two fixings in each wheel arch and one tip fixing each side, remove nine fixings securing bumper lower edge and under trays, pull bumper tip outboard to release from body disconnect reversing sensors and slide bumper rearwards.

### GT BUMPER REMOVAL

Remove the fixings securing the rear light side trims, remove trims and remove the bumper fixing hidden behind, remove two fixings in each wheel arch and one tip fixing each side, remove two fixings securing bumper lower edge and under tray, unclip the lower edge diffuser to reveal the remaining five fixings and remove, pull bumper tip outboard to release from body disconnect reversing sensors and slide bumper rearwards.

### TOWBAR INSTALLATION

1. Remove the fixings securing the rear exhaust silencer hanger to crash beam and support to prevent damage. (If the vehicle is fitted with tail pipes either side remove both hangers).
2. Remove the rear crash beam (This is **NOT** refitted with Towbar assembly) and retain fixings and gaskets.
3. Place Item **A** onto the Towbar mounting points along with the rear crash beam gaskets and fit with original fixings (Item **X** on illustration) and Item **H** (118Nm).
4. Refit exhaust silencer hanger to Item **A** using Items **G**.
5. Cut the bumper **under tray only** to original BMW markings to Suit Towbar and Flip up electrical plate.
6. Refit rear bumper.
7. Using Item **D** with Item **F** bolt Item **B** and Item **E** to Item **A** and fully tighten.
8. Refit under trays and diffuser, (diffuser on GT ONLY).
9. Using Item **C** bolt the ball bracket (not supplied in this kit) to face plate and fully tighten.

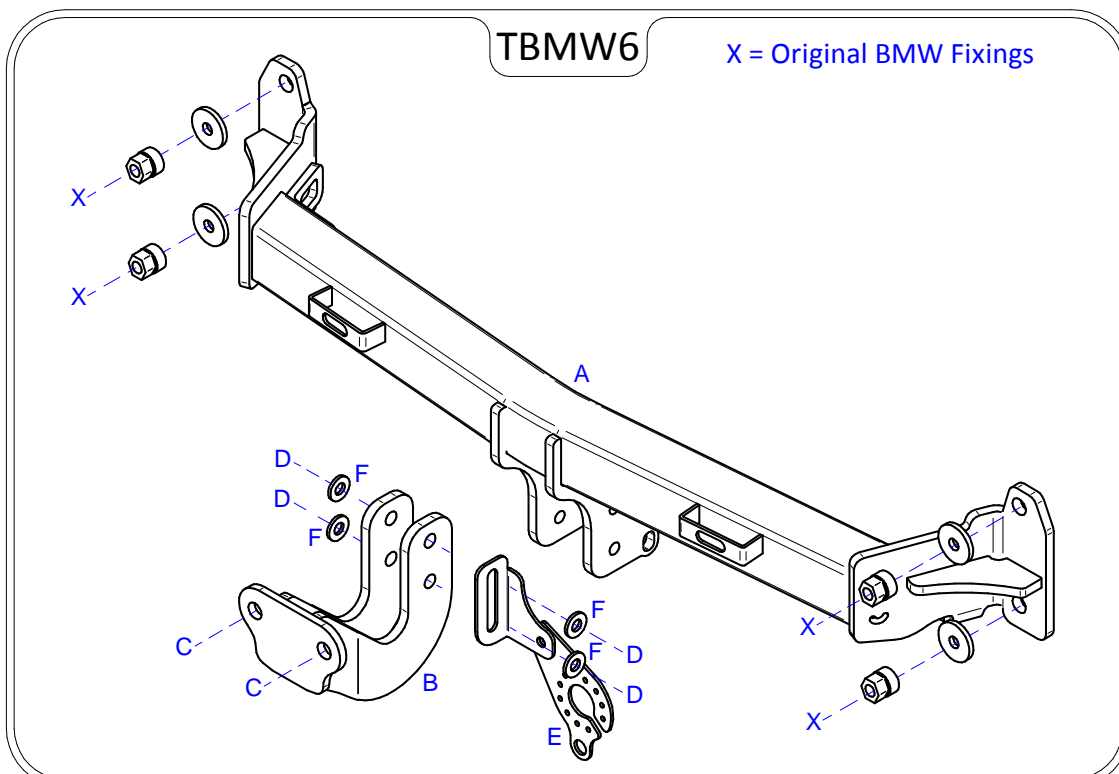

### Note:

1. Recommended Torque Setting for M12 Grade 10.9 -139 Nm. (For other Torque Settings see notes overleaf.)
2. Nose load limits and vehicle manufacturers trailer / caravan weight limits must be observed.