

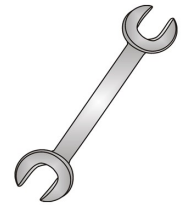

Tow-Trust Towbars

Important: Please read General Notes overleaf before fitting



Issue 2

TCN7 CITROEN C3 AIRCROSS 2017> / VAUXHALL CROSSLAND X 2017>

Item	Qty	Description	Item	Qty	Description
A	1	TCN7 Crossmember	D	2	M16 x 50 Bolts & Nyloc Nuts
B	2	Handed Side Arms	E	4	M10 Small Metal Cage Nuts
C	1	Extension	F	6	M10 x 35 Bolts & S/P Washers
			G	4	M10 x 40 Bolts, 2 Nyloc Nuts and 2 S/P Washers
			H	2	M8 x 30 (10.9) Bolts & S/P Washers
			J	2	M12 x 40 Bolts & Nyloc Nuts
			K	1	M12 x 120 Bolt & Nyloc Nut
			L	2	10 x 40 Flat Washers
			M	12	10 x 25 Flat Washers
			N	2	8 x 25 H/D Flat Washers
			P	4	12 x 25 Flat Washers
			Q	1	30mm O/D x 60mm Long Spacer Tube

BUMPER REMOVAL:

1. Remove the rear light clusters, two fixings on each cluster. Remove four fixings from the bumper lower edge, remove three fixings from each wheel arch liner and roll back liner. Carefully unclip wheel arch trim to reveal one tip fixing each side and remove. Carefully release the bumper from the vehicle body work and pull rearwards.

TOWBAR INSTALLATION:

2. Remove the upper inner fixing from the rear impact beam and discard. Remove the tape cover the Towbar mounting points on the outside face of each chassis member and insert Items E.
3. Using Item F with Item M and Item L as a spacer fix Items B to the chassis vertical mounting point.
4. Using Item F with Item M fix Items B to outside face mounting points in each chassis.
5. Using Item H with Item N fix Item A to the rear panel mounting points sandwiching the rear impact beam.
6. Using Item G with Item M fix Item A to Items B.
7. Using Item J with Item P and Item K with Item P fix Item C to Item A ensuring Item Q is mounted between the lower mounting point.
8. Using Item D fix your desired ball bracket and wiring plate (Not supplied in this kit) to Item C.
9. Fully tighten all fixings ensuring the Towbar is rigid, square and secure.
10. Cut the rear bumper as per the correct sketch for your chosen vehicle below.
11. Refit the rear bumper.

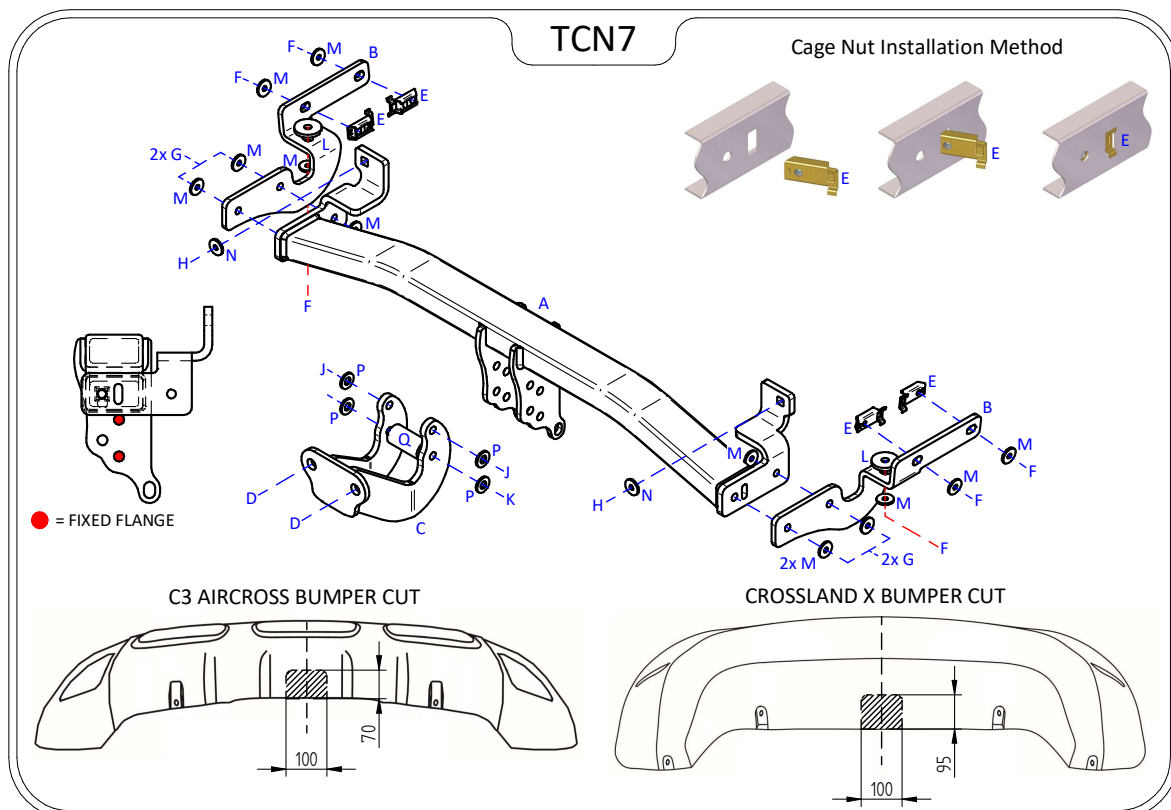

Note:

1. Torque Settings see notes overleaf.
2. Nose load limits and vehicle manufacturers trailer / caravan weight limits must be observed.