

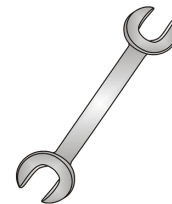

Tow-Trust Towbars

Important: Please read General Notes overleaf before fitting



Issue 7

TF159A Ford Transit Chassis Cab 2000>

Item	Qty	Description	Item	Qty	Description
A	1	Crossmember	D	2	M16 x 60 Bolts & Nyloc Nuts
B	2	Side Arms	E	6	M12 x 100 Bolts & Nyloc Nuts
C	4	19 x 58 Spacer Tubes	F	6	M12 x 35 Bolts 4 Nyloc Nuts & 2 S/P Washers
			G	4	12 x 40 Flat Washers
			H	2	12 x 25 Flat Washers

1. Remove the two existing bolts securing the towing eye.
2. Open the two lower existing holes and the rearmost upper hole out to 20mm in the outer face only of the right hand chassis member.
3. Open out to 20mm the upper rearmost hole in the outer face only of the left hand chassis.
4. Using item E with item G and item H loosely bolt item B to the inside face of each chassis member. (Bolt through the towing eye on the left, and use item C inside the chassis on the three holes the right and the upper hole on the left).
5. Using item F bolt item A to item B.
6. Using item D bolt the ball bracket and wiring plate (not supplied in this kit) to the mounting plate.
7. Fully tighten all nuts and bolts and ensure the Towbar is rigid and secure.

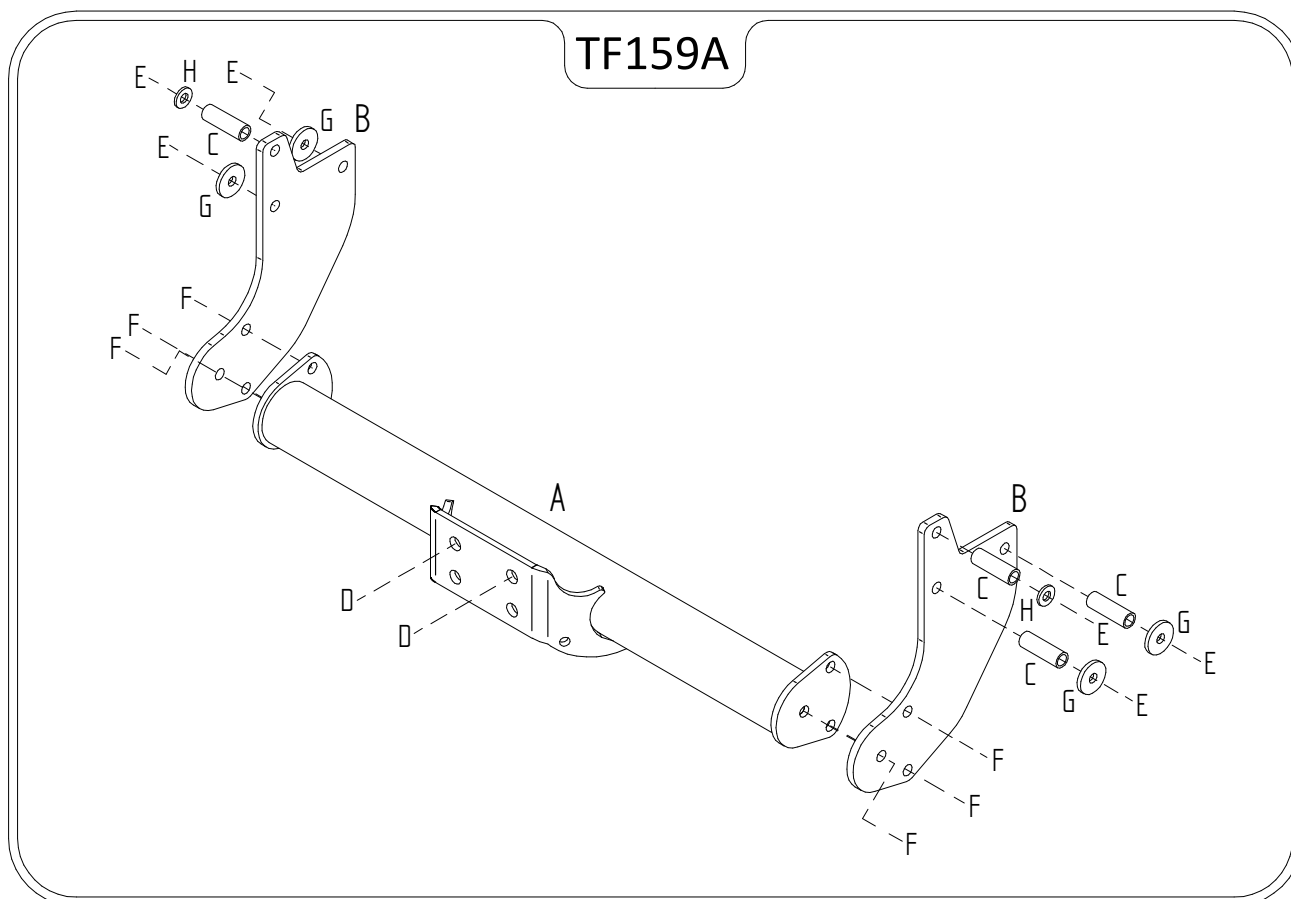

note:

1. Recommended Torque Setting for M12 Grade 10.9 -130 Nm. (For other Torque Settings see notes overleaf.)
2. Nose load limits and vehicle manufacturers trailer / caravan weight limits must be observed.