

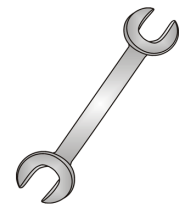

Tow-Trust Towbars

Important: Please read General Notes overleaf before fitting



Issue 7

TFD2VK FORD KUGA 2008>

Item	Qty	Description	Item	Qty	Description
A	1	Crossmember	D	1	Flip Up Socket Plate (TTFP/RH)
B	2	Handed Side Arms	E	10	M10 x 35 Bolts, 4 Nuts & 10 S/P Washers
C	1	6214 Detachable Neck	F	2	M12 x 25 Bolts & S/P Washers
			G	2	M12 x 22 Bolts & S/P Washers
			H	4	12 x 25 Flat Washers
			J	4	10 x 40 Flat Washers

1. Remove the rear bumper, **2008 - 2013** one fixing either side of boot opening, four fixings along lower edge of bumper, three fixings around wheel arch, fold back wheel arch liner to reveal one remaining fixing, unplug the fog lights. Bumper tips will need to be pulled out sideways and then rearwards.
2. **2013>** Remove the rear light clusters. Remove the rear bumper four fixings around boot opening, four fixings on the lower edge, five fixings around each wheel arch, fold back wheel arch liner and unclip wheel arch trim to reveal one fixing behind, Bumper tips will need to be pulled out sideways and then rearwards.
3. Remove the bumper impact beam and towing eye. (impact beam is not refitted with Towbar)
4. Insert items **B** into the correct chassis and using item **E** and item **J** loosely bolt in place.
5. Using original fixings re-fit the towing eye to the vehicle and fully tighten.
6. Using item **E** bolt item **A** between items **B**.
7. Using item **F** with **H** and item **G** with **H** bolt item **C** with item **D** to item **A**.
8. Fully tighten all nuts and bolts and ensure Towbar is rigid and secure.
9. Cut the bumper centrally on the lower face SEE SKETCH (Trim to suit if required) and refit.

NOTE: 2013> FACELIFT: No bumper cut required.

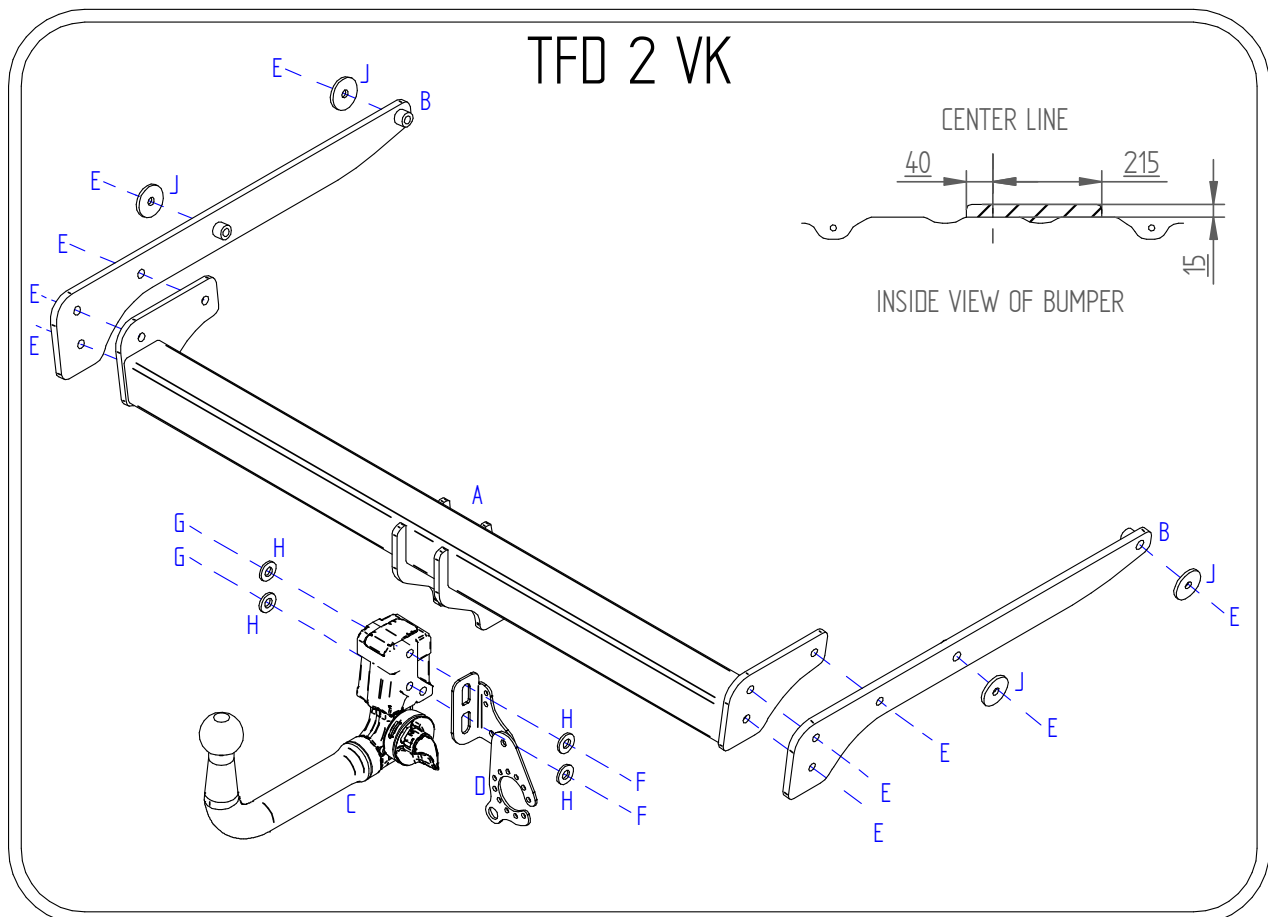

Note:

1. Recommended Torque Setting for M12 Grade 10.9 -139 Nm. (For other Torque Settings see notes overleaf.)
2. Nose load limits and vehicle manufacturers trailer / caravan weight limits must be observed.