



Tow-Trust Towbars

Important: Please read General Notes overleaf before fitting
Issue: 1



Fitting
Instruction

TLAN13VK Range Rover III (L460) 2022> & Range Rover Sport III (L461) 2023> (With and Without OEM Towing Panel. Ordered using vehicles VIN)

Item	Qty	Description	Item	Qty	Description	Torque Setting
A	1	TLAN13 Crossbar	G	3	M12 x 25 (10.9) Bolts & S/P Washers	130 Nm
B1	1	Left Hand Rear Panel Bracket	H	3	M12 x 30 (10.9) Bolts & S/P Washers	130 Nm
B2	1	Right Hand Rear Panel Bracket	J	4	M12 x 55 (10.9) Bolts & S/P Washers	130 Nm
C1	1	Left Hand Reinforcement Bracket	K	4	M12 x 90 (10.9) Bolts & Serrated Flange Nuts	130 Nm
C2	1	Right Hand Reinforcement Bracket	L	6	M14 x 40 Bolts & S/P Washers	150 Nm
D1	1	Left Hand Captive Plate	M	14	12 x 25 (HD) Flat Washers	
D2	1	Right Hand Captive Plate	N	6	14 x 27 Flat Washers	
E	1	6#16 Detachable Neck	P	1	M8 x 30 Bolt & Nyloc Nut	15 Nm
F	1	Right Hand Three Hole Flip Up Socket Plate Bracket	Q	2	8 x 15 Flat Washers	
F1	1	Flip Up Socket Plate	R	3	8 x 25 Flat Washers	
			S	1	Neoprene Washer	

Bumper Removal Range Rover L460:

- Remove the middle and lower fixings from the mudguards if installed. The top fixing remain in place and the mudguards will remain attached to the bumper when removed.
- Remove the remaining two fixings if the vehicle had mud guards or three fixings on vehicles without separating the wheel arch trim.
- Remove the four fixings from the central towing eye panel and remove. This will not be refitted if the **OEM** Towing panel is to be fitted. If not cut the panel as shown in **Figure 1**.
- Remove the seven fixings now revealed along the lower edge as well as the fixings located at the lower edge of each wheel arch.
- Open the upper and lower tailgate, then unclip the trim from around each tail light plus the lower section retained by two push-in clips going sideways then release from the body.
- Disconnect the reversing sensor loom from the nearside this can be a little tricky to access, some fitters may prefer to free the bumper first.
- Pull the bumper out sideways and rearwards to remove.
- Lower the exhaust by removing the rear hangers from the body and support.
- Remove the rear beam, six vertical fixings and four fixings in the rear panel. **Note:** - This is not refitted with the Towbar assembly.

Bumper Removal Range Rover Sport L461:

- Remove the three fixings from the mudguards if installed. Remove the three fixings securing the wheel arch trim on models without.
- Remove the wind deflectors from the top edge of the wheel arch trim which extends to the outside, three fixings and one clip each side.
- Pull the wheel arch trim out and remove the three fixings and one tip screw from each side.
- Remove the four fixings from the central towing eye panel and remove. This will not be refitted if the **OEM** Towing panel is to be fitted. Some **Models** it is possible to **remove/refit** the removable panel when **Towing** or **Not Towing**. **Always Check** if this is possible or what the vehicle owner's preference is. If not cut the panel as shown in **Figure 2**.
- Remove the four fixings now revealed along the lower edge as well as the fixings located at the lower edge of each wheel arch.
- Open the tailgate, then unclip the trim from the centre of the bumper. Remove the now revealed six push-in clips.
- Disconnect the reversing sensor loom from the nearside this can be a little tricky to access, some fitters may prefer to free the bumper first.
- Pull the bumper out sideways and rearwards to remove.
- Remove the lower bumper edge retaining bracket, five fixings.
- Remove the bar bridging the rear suspension mounted to the subframe to allow the exhaust and **Ad-Blue** tank if present to be lowered, one fixing each side.

Range Rover Sport L461 Ad-Blue Models Only:

- Remove the metal lower tank shield, four fixings. Then supporting the tank remove the four fixings and lower the tank slightly.
Note: Some fitters may prefer to loosen these fixings allowing the tank to pivot enough to access the rear beams vertical fixings.

Range Rover Sport L461 All Models:

- Lower the exhaust by removing the rear hangers from the body and support.
- Remove the rear beam, six vertical fixings and four fixings in the rear panel. **Note:** - This is not refitted with the Towbar assembly.

Towbar Installation For All Models (L460 & L461):

Note: Before installing the Towbar into the chassis it is recommended that the wiring kit (VSK) is fitted and threaded from inside the vehicle through the grommet to the outside.

- Using **Figure 4** as a guide loosely assemble Item **A** with items **B1, B2, C1, C2, D1** and **D2** using items **K** with items **M**.
- Using **Figure 5** as a guide slide the assembly into the chassis opening and loosely fix in place items **B1, B2, C1** and **C2** in place using items **J** with items **M** into the rear panel mounting points.
- Using **Figure 5** as a guide loosely fix items **D1** and **D2** using items **L** with items **N** into the vertical mounting points.
- Loosely fix item **E** to item **A** on the correct setting for the vehicle as shown in **Figure 3** using items **G** with items **M** and items **H** with items **M** with item **F** as shown in **Figure 6**.
- Loosely fix item **F1** to item **F** using item **P** with items **Q, S** and **R**. **Note:** Use as many of item's **R** as required to position item **F1** to suit the application best.
- Fully tighten all the fixings ensuring the Towbar is ridged, square and secure.

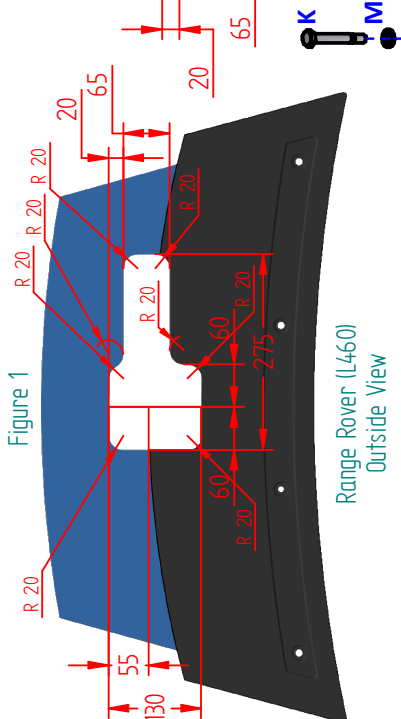
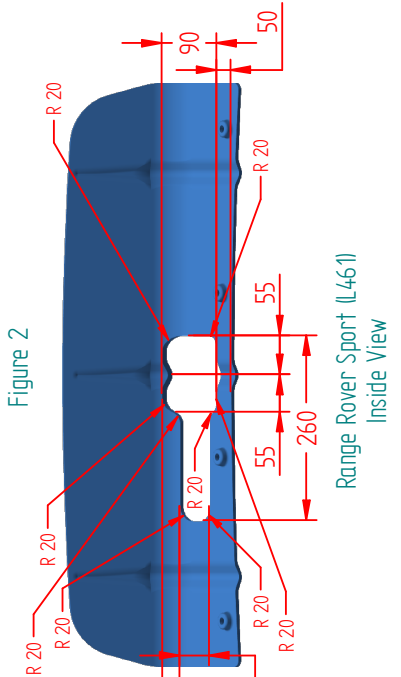
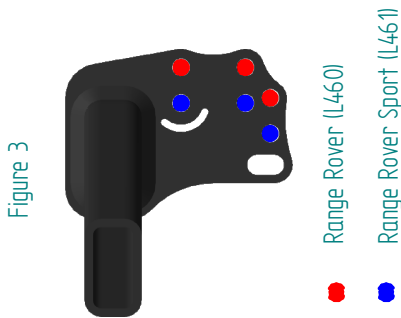

● Range Rover (L460)
● Range Rover Sport (L461)

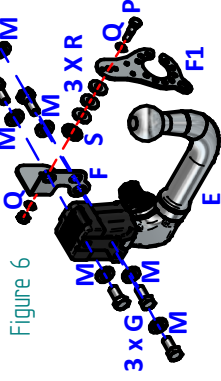
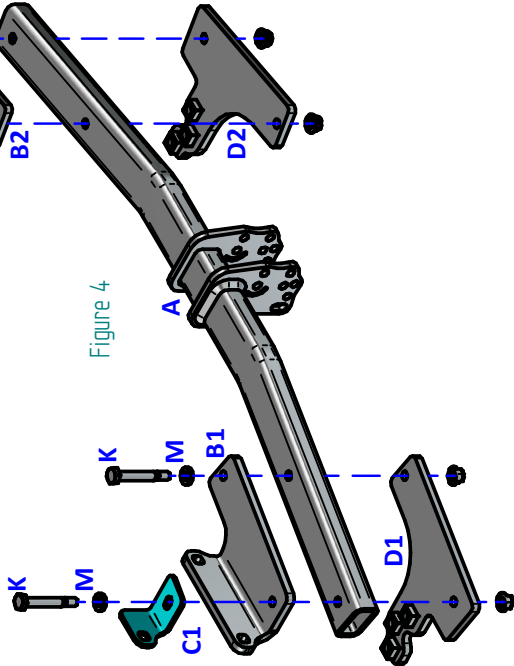
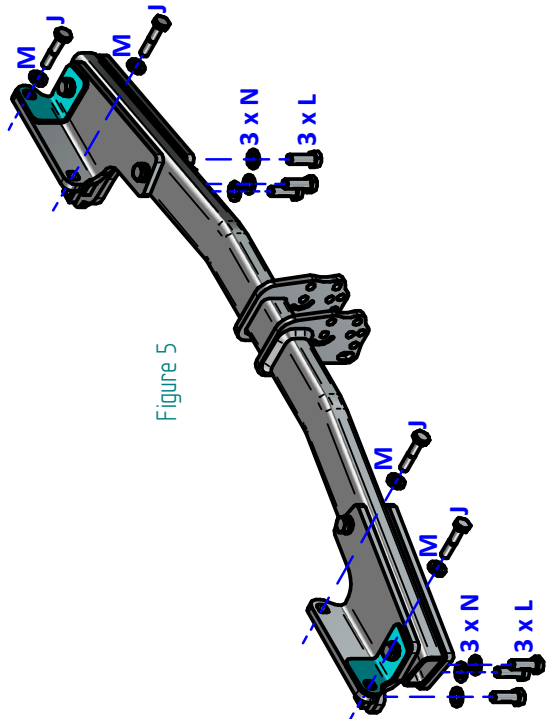

Notes:

1. For Torque settings see the column next to each item in the list.
2. Nose load limits and vehicle manufacturer's trailer / caravan weight limits must be observed.
3. We recommend the use of PRO-TOW Couplings with all our products.