

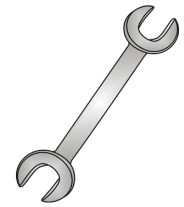

Tow-Trust Towbars

Important: Please read General Notes overleaf before fitting



Issue 2

TN10HK NISSAN JUKE 2WD 2010>

Item	Qty	Description	Item	Qty	Description
A	1	Crossmember	F	1	Socket Plate (SP1)
B	2	Handed Side Arms	G	4	M12 x 40 Bolts & S/P Washers
C	4	Angle Brackets	H	4	M10 x 40 Bolts & S/P Washers
D	2	Clamp Plates	J	4	M12 x 35 Bolts, 2 Nuts & 4 S/P Washers
E	1	Detachable Housing	K	4	10 x 40 Flat Washers
			L	1	M12 x 30 Bolt & S/P Washer
			M	4	12 x 40 Flat Washers
			N	1	12 x 25 Flat Washers

BUMPER REMOVAL:

Open the tailgate to reveal four fixings and remove, two fixings in each wheel arch and remove plastic liner, unclip plastic wheel arch edge trim to reveal one tip fixing each side, five fixings along the lower edge. Unclip bumper from tips and then pull rearward. Unscrew fog light bulb and remove. Remove the rear impact beam (impact beam is replaced by Towbar), Refit all fixings on rear panel to prevent water damage.

Remove four fixing holding lower black trim and cut. SEE SKETCH.

TOWBAR INSTALATION:

1. Locate all Towbar mounting points and clear off all mastic/under seal, ensuring chassis members are clean.
2. Locate Item **D** into each chassis member and using Item **H** and Item **K** loosely bolt Items **C** to all lower face mounting points.
3. Insert Items **B** into each correct chassis members and fix in place using Items **G** and Items **M** through Items **C** and the outside face of each chassis.
4. Using Item **J** bolt Item **A** between side arms (Item **B**).
5. Using Item **L** and Item **N** bolt Item **F** to Item **A**.
6. Fully tighten all nuts and bolts ensuring Towbar is rigid square and secure.
7. Refit lower black trim and bumper ensuring fog light is plugged back in before bumper is fully refitted.

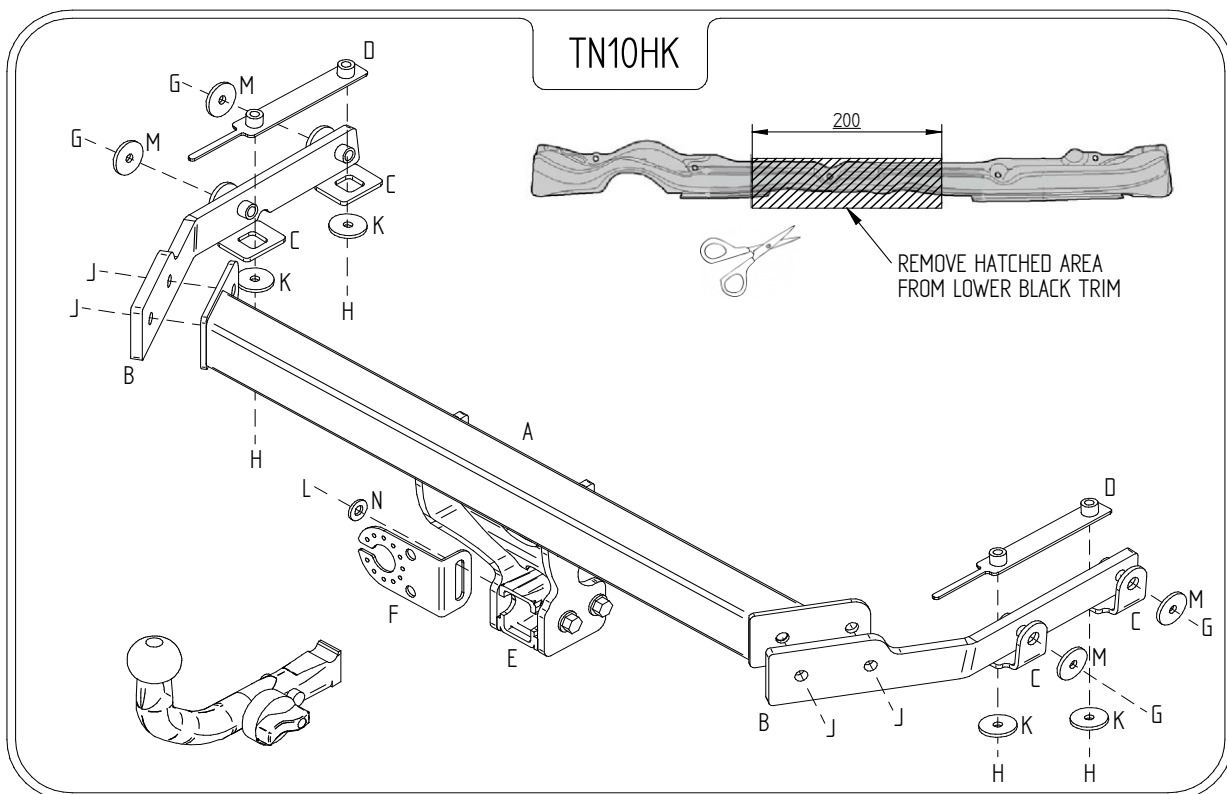

Note:

1. Recommended Torque Setting for M12 Grade 10.9 - 130 Nm. (For other Torque Settings see notes overleaf.)
2. Nose load limits and vehicle manufacturers trailer / caravan weight limits must be observed.