

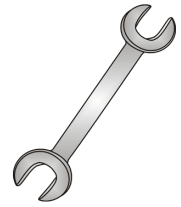

Tow-Trust Towbars

Important: Please read General Notes overleaf before fitting



Issue 10

TP1 Peugeot 207 3 & 5 Door Hatch 2006> Peugeot 207 Van 2007> Citroen C3 Picasso 2009>

Item	Qty	Description	Item	Qty	Description
A	1	Crossmember	E	2	M16 x 50 Bolts, Nuts & S/P Washers
B	2	Handed Side Arms	F	4	M12 x 35 Bolts, 2 Nuts & 4 S/P Washers
C	2	Angle Brackets	G	8	M10 x 35 Bolts, 2 Nuts & 8 S/P Washers
D	1	Extension Bar	H	2	M12 x 85 Grade 10.9 Bolts & Nyloc Nuts
			J	4	M10 Caged Nuts (Small)
			K	10	10 x 30 Flat Washers
			L	4	12 x 25 Flat Washers
			M	2	16 x 27 Flat Washers

- Temporarily remove the two fixings from the lower edge of the bumper.
- Remove the tape covering the existing two holes in the outer face of each chassis member and the existing hole in the lower face of each chassis member.
- Locate item J into the square holes provided in the outer face of each chassis member.
- Using item G with item K loosely bolt item B to the left hand outer face of the chassis member.
- Carefully locate item A inside the bumper and over the exhaust.
- Using item G with item K loosely bolt item B to the right hand outer face of the chassis member.
- Using item F bolt item A to item B.
- Using item G with item K loosely bolt item C to the existing threaded holes in the lower face of each chassis member and also to item B.
- Using item H with item L bolt item D to item A.
- Using item E bolt the ball bracket and wiring plate (not supplied in this kit) to the mounting plate. Note: Item M may be required under the bolt head when not using PRO-TOW Couplings to ensure the bolt doesn't hit the bumper.
- Fully tighten all nuts and bolts and ensure the Towbar is rigid and secure.
- Replace fixings along lower edge of the bumper.

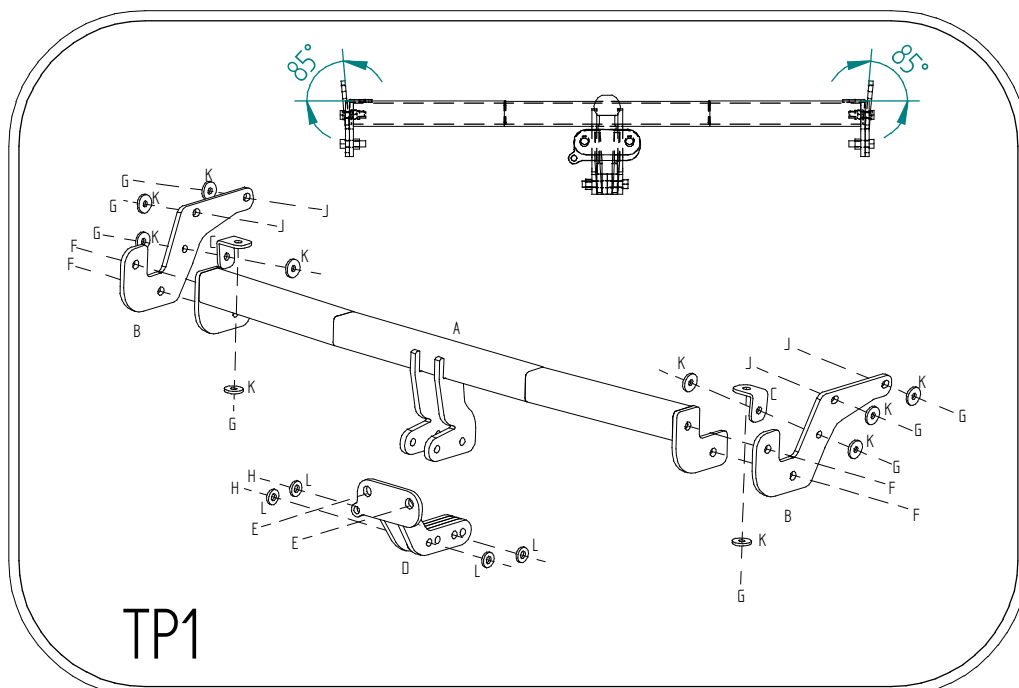

Note:

- Recommended Torque Setting for M12 Grade 10.9 -130 Nm. (For other Torque Settings see notes overleaf.)
- Nose load limits and vehicle manufacturer's trailer / caravan weight limits must be observed.