

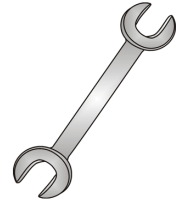

Tow-Trust Towbars

Important: Please read General Notes overleaf before fitting



Issue 7

TR818 Renault Master Chassis Cab 1998-2010 Vauxhall Movano Chassis Cab & Pick Up 1998-2010

Item	Qty	Description	Item	Qty	Description
A	1	Towbar	D	2	M16 x 50 Bolts, Nuts & S/P Washers
B	1	Coupling Spacer	E	4	M10 x 45 Bolts & S/P Washers
C	1	R/H & L/H Hand Side Arms	F	8	M12 x 40 Bolts, 2 Nuts & 8 S/P Washers
			G	4	10 x 30 Flat Washers
			H	10	12 x 25 Flat washers

1. Remove the two inner bolts securing the towing eye to the left hand chassis (these are no longer required). NOTE: Towing eyes are not always fitted.
2. Using Item E with Item G loosely bolt Item A to the existing threaded holes in the side of each chassis.
3. Using Item F with Item H loosely bolt Item C to the existing threaded holes in the bottom face of each chassis and to the two holes in Item A.
4. Using Item D bolt the ball bracket and wiring plate (not supplied in this kit) to the mounting plate.
5. Fully tighten all nuts and bolts and ensure the towbar is rigid and secure.

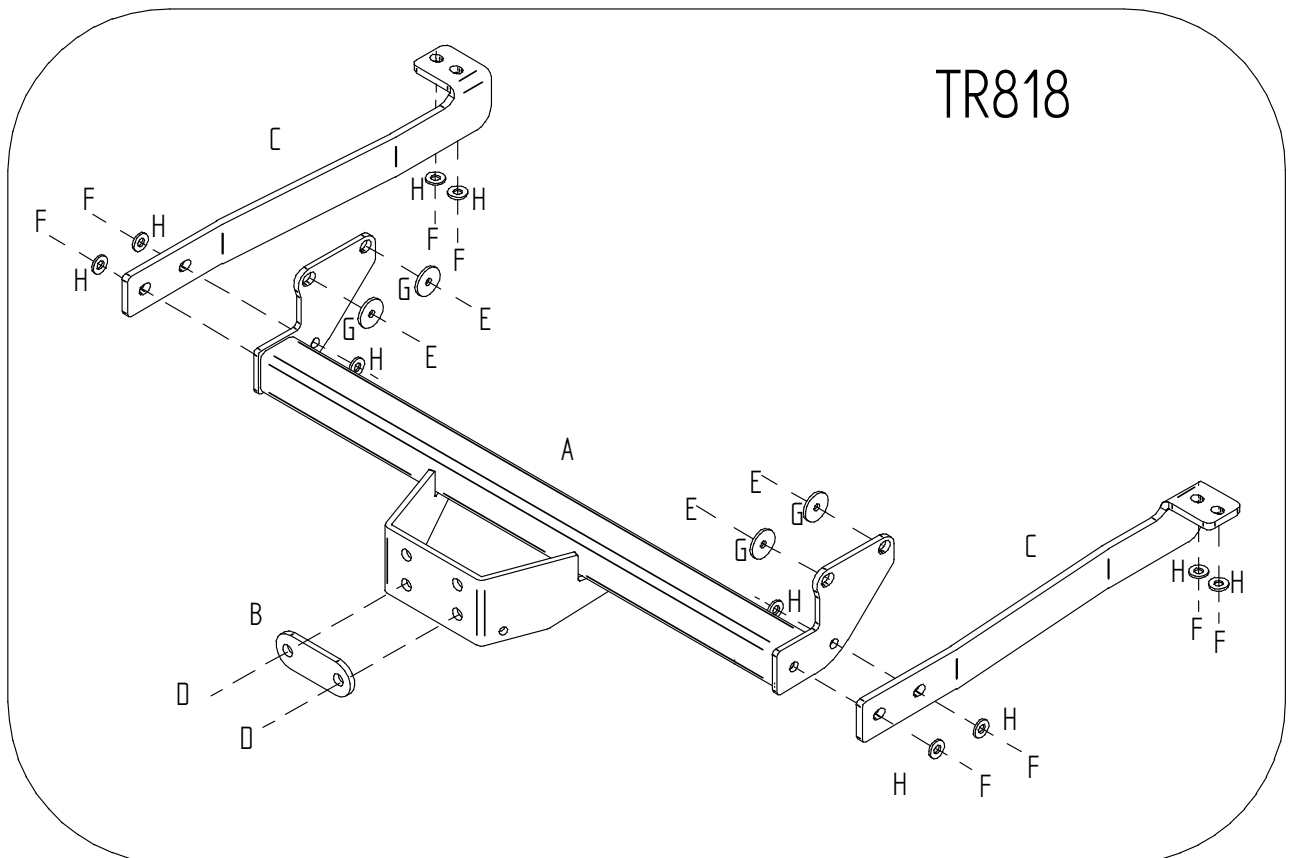

Note: nose load limits and vehicle manufactures trailer / caravan weight limits must be observed.