

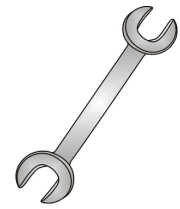

Tow-Trust Towbars

Important: Please read General Notes overleaf before fitting



Issue 5

TV357 Vauxhall Astra Hatchback 2004 - 2009

Item	Qty	Description	Item	Qty	Description
A	1	Crossmember	G	2	M16 x 50 Bolts, Nuts & S/P Washers
B	1	Extension Bar	H	6	M10 x 90 Bolts, Nuts & S/P Washers
C	1	Large L/H Clamp Plate	J	2	M12 x 85 Grade 10.9 Bolts & Nyloc Nuts
D	1	Small R/H Clamp Plate	K	6	10 x 25 Flat Washers
E	4	19 x 56 Spacer Bushes	L	4	12 x 25 Flat Washers
F	2	19 x 58 Spacer Bushes			

1. Temporarily remove the rear boot edge panel and boot floor covering. Pull the side trims out of the way to reveal the six dimples in the boot floor.
2. Remove mastic compound from boot floor to allow Item C to seat correctly.
3. Drill the six dimples out to 20mm through the top skin only.
4. Locate Item E and Item F down into each chassis and place Item C and Item D over each set of spacer bushes. (Remove all mastic from boot floor so that clamp plates fit to bare metal.)
5. Place Item H down through the clamp plates and spacer bushes.
6. Temporarily remove the two rubbers from the rearmost exhaust so that the exhaust is lowered out of the way.
7. Using Item K and the nuts and washers provided loosely bolt Item A to the bolts already in place.
8. Fully tighten all nuts and bolts and ensure the towbar is rigid and secure.
9. Refit exhaust rubbers. (On sports models it may be necessary to bend the exhaust hangers down slightly to give clearance for the towbar.)
10. Using Item J with Item L bolt Item B to Item A.
11. Using Item G bolt the ball bracket and wiring plate (not supplied with this kit) to the mounting plate.

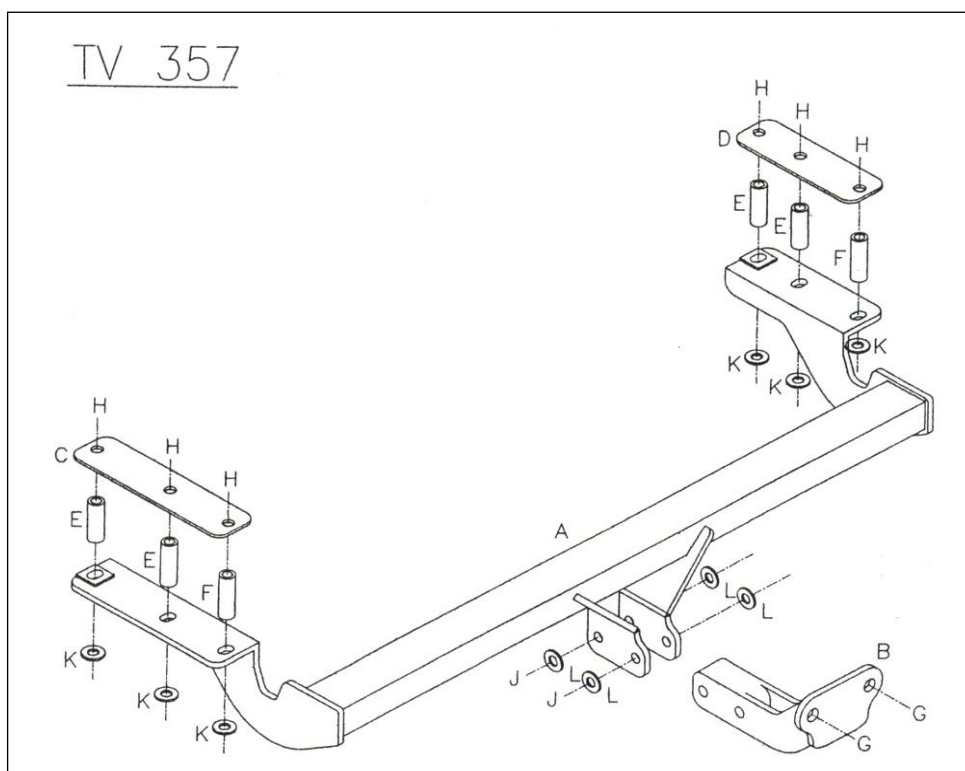

Note:

1. Recommended Torque Setting for M12 Grade 10.9 -139 Nm. (For other Torque Settings see notes overleaf.)
2. Nose load limits and vehicle manufacturers trailer / caravan weight limits must be observed.