

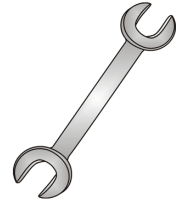

Tow-Trust Towbars

Important: Please read General Notes overleaf before fitting



Issue 1

TV7SN VAUXHALL ASTRA GTC 3 DOOR HATCH 2011>

Item	Qty	Description	Item	Qty	Description
A	1	Crossmember	D	2	15mm Spacer Plates
B	2	Side Arms	E	4	M10 x 30 Bolts & S/P Washers
C	1	ACS8 / 9208 Swan Neck	F	4	M12 x 35 Bolts, Nuts & S/P Washers
			G	2	M12 x 110 Grade 10.9 Bolts & Nyloc Nuts
			H	8	12 x 25 Flat Washers
			J	2	10 x 25 Flat Washers
			K	2	10 x 40 Flat Washers
			L	1	VASP8 L/H Socket Plate

BUMPER REMOVAL:

1. First remove each rear light cluster, two fixings found inside the boot behind trim, remove two fixings along the lower edge of the rear bumper and three fixings around each wheel arch, remove number plate and the two fixings found behind, last of all one fixing found beneath each light cluster. Pull bumper tips outward then rewards to remove.

TOWBAR INSTALLATION:

1. Remove and discard the rear crash beam (Hand to customer).
2. Lower the rear silencer to gain access to the vertical Towbar mounting points.
3. Insert Items **B** into each chassis member and loosely fix in place using Items **E** and Item **K** on the forward most and Item **E** and Item **J** on the rearmost mounting points.
4. Using the original M10 fixings fix Item **A** to the rear panel.
5. Using Items **F** and Items **H** fix Item **A** to Items **B**.
6. Using Item **G** with Item **H** and Item **D** fix Item **C** and Item **L** to Item **A**.
7. Fully tighten all nuts and bolts ensuring Towbar is rigid square and secure. (We at Tow-Trust advise you fit the wiring into the vehicle before the bumper gets refitted).
8. Cut the rear bumper SEE SKETCH. Refit exhaust, bumper and number plate.

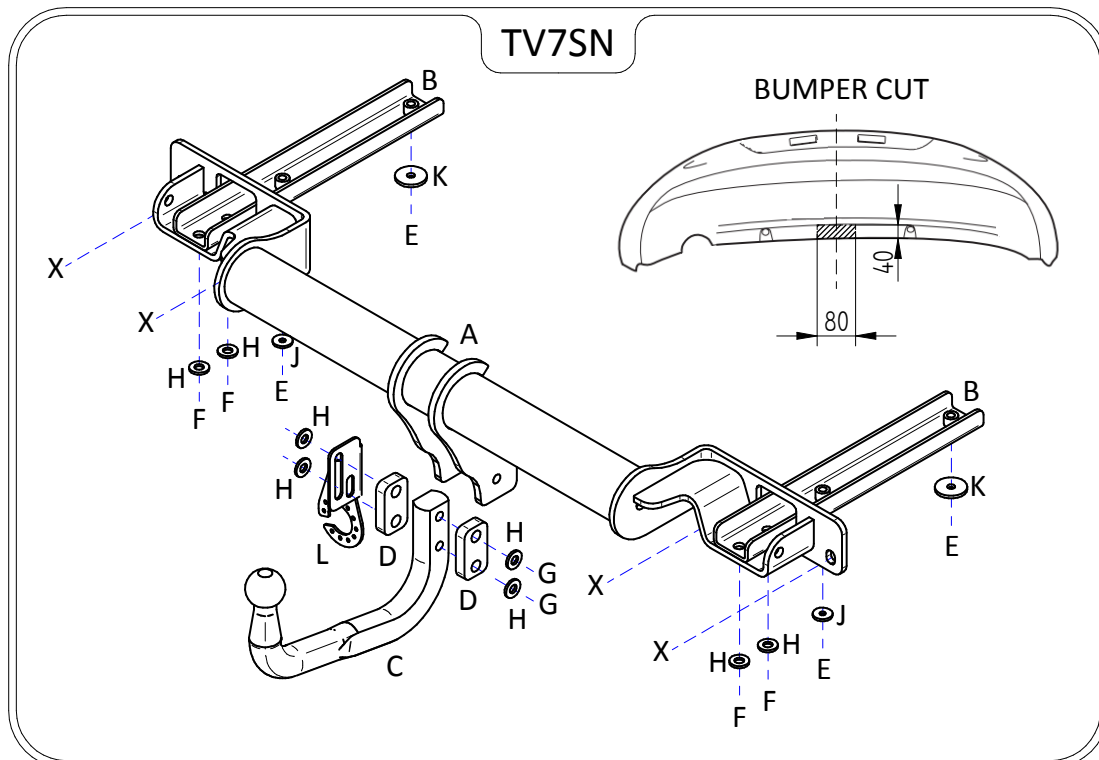

Note:

1. Recommended Torque Setting for M12 Grade 10.9 -139 Nm. (For other Torque Settings see notes overleaf.)
2. Nose load limits and vehicle manufacturers trailer / caravan weight limits must be observed.