

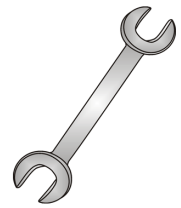

# Tow-Trust Towbars

Important: Please read General Notes overleaf before fitting



Issue 8

## TVV529 VOLVO XC60 2008> XC70 2007>

Item	Qty	Description	Item	Qty	Description
A	1	Crossmember	D	2	M16 x 50 Bolts, Nuts & S/P Washers
B	1	Extension Bar	E	12	M12 x 40 Bolts, 6 Nyloc Nuts & 6 S/P Washers
C	2	Handed Side Arms	G	4	12 x 40 Flat Washers
			H	4	12 x 25 Flat Washers

1. Remove the rear bumper, two fixings on the bottom edge, five fixings in each wheel arch and one fixing either side of the boot opening, unclip the corners and pull rearwards.
2. Cut a section from the lower edge of the bumper. SEE SKETCH. If required trim to suit.
3. Remove the crash beam; this is not refitted with Towbar assembly.
4. Lower exhaust and support to prevent damage. (On the XC60 remove the heat shield to gain access to the Towbar mounting points).
5. Remove the tape from Towbar mounting points found on the inside face of each chassis member.
6. Insert items C into each chassis member and loosely fix in place using item E with item G.
7. Using item E fix item A between items C (For XC70 models Item A will need rotating 180 degrees from the image shown below, to give sufficient Tow Ball clearance).
8. Using item E with item H fit item B to item A.
9. We advise that you install your desired wiring into the vehicle now before refitting the bumper.
10. Using item D bolt the ball bracket and wiring plate (Not supplied in this kit) to item B.
11. Fully tighten all nuts and bolts until Towbar is rigid and secure.
12. Refit exhaust, heat shield and bumper.

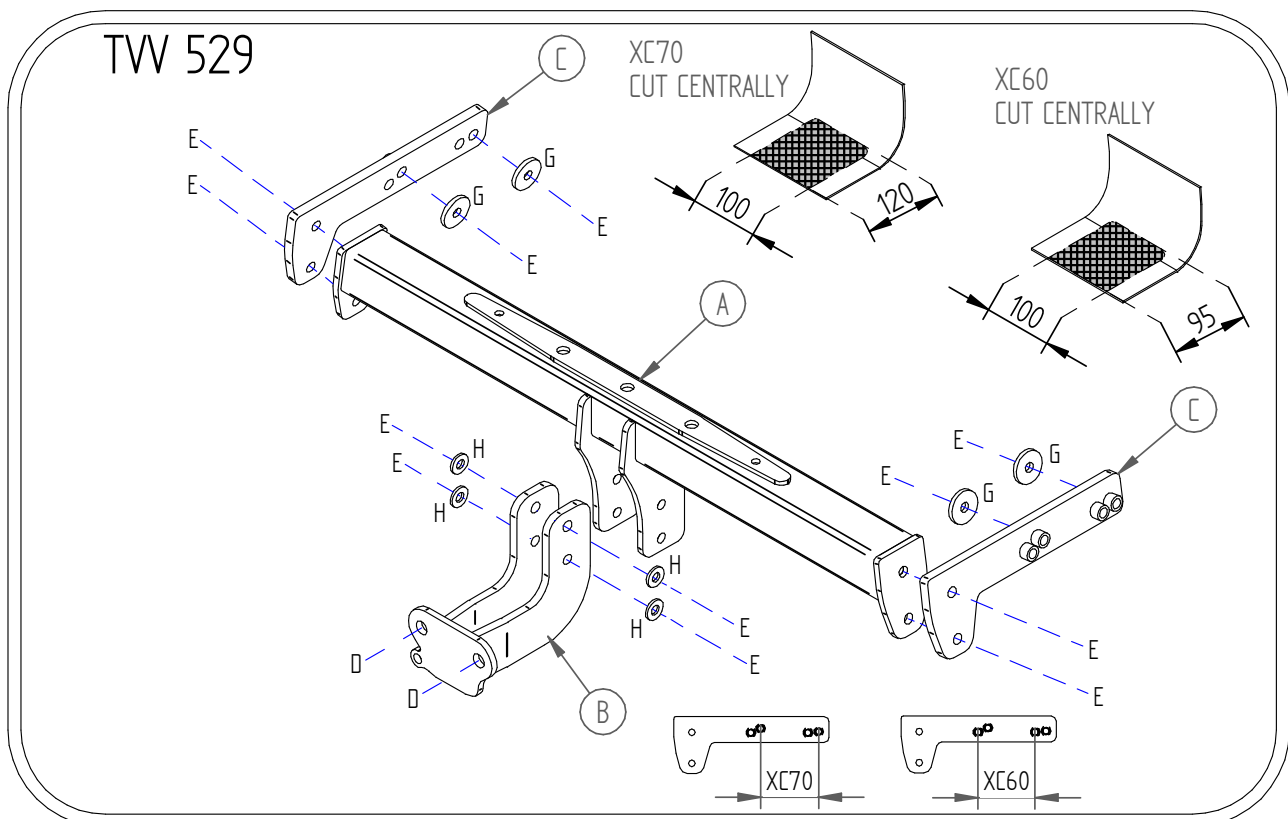

- Note:**
1. Recommended Torque Setting for M12 Grade 10.9 -130 Nm. (For other Torque Settings see notes overleaf.)
  2. Nose load limits and vehicle manufacturer's trailer / caravan weight limits must be observed.